



# SAM2-24 Shear Aligning Magnalock®

**Application** - 600 lb. holding force Shear Aligning Magnalock mounts fully concealed and is ideal for smaller applications, like cabinet doors and sliding closet doors. 24VDC only.

## Features and Benefits

- Instant release circuit - no residual magnetism
- Mounts easily with a minimum of tools
- Fully sealed electronics - tamper proof and weatherproof
- Mounted using steel machine screws
- Architectural brushed stainless steel finish (US32D/630)
- All ferrous metal surfaces plated to MIL specification
- Six feet [1.8m] of jacketed, stranded conductor
- Smaller dimensions for difficult installation areas
- UL Listed



## Specification Data

Holding Force: 600 lbs. [272 Kg.]  
 Current Draw and Voltage: 62mA at 24VDC only  
 Operating Temperature: -40 to +140F [-40 to +60C]  
 Shipping Weight: 2.5 lbs.  
 Warranty: MagnaCare Lifetime Replacement Warranty

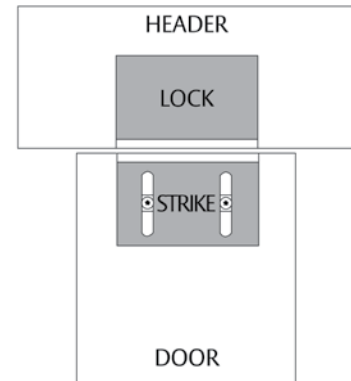

## How To Order

Part #	Description
SAM2-24	SAM2 Magnalock 24VDC

U.S. Patents:  
 #6,007,119, #6,135,515  
 NEMA: 4X IEC: IP 66

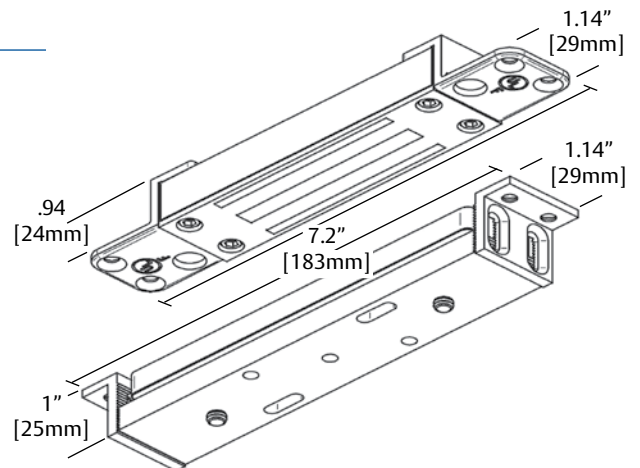

## Magnalock Patents, Approvals and Listings

- Patent Numbers: #4,682,801, #6,135,515, #6,007,119
- BondSTAT Magnetic Bond Sensor - Patent Pending
- Underwriter's Laboratories (US and Canada): Files SA6635, BP7041 and R13976
- UL 10B & UL 10C, UL 294 & NFPA 101
- California State Fire Marshal: 3774-0923:101
- City of New York MEA: 251-95E & 254-95E
- CE: EN 50081-1 (92) & EN 61000-6-2 (99)